

Trade Mark:
CRYSTAL WORLD INC

Product Name: Ceiling lamp
Model :9612P11-1-128
120Vac, 60Hz,AC ONLY
Lamp Size:D11"*H10"~H69"

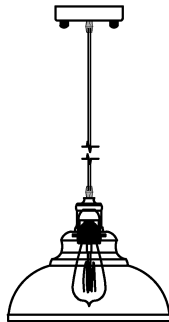

CEILING LAMP ASSEMBLY INSTRUCTIONS

1. Place fixture (1) onto Crossbar (EE).
secure with Mounting screw (DD).

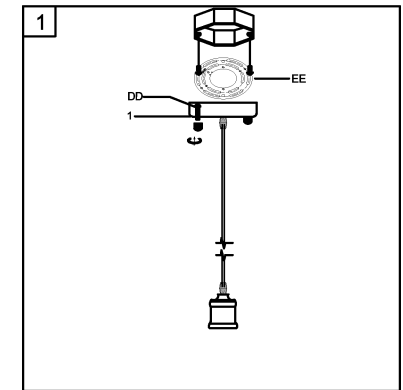

Hardware Used

DD Mounting screw  X 2

2. Please fix part (2) with part (1).

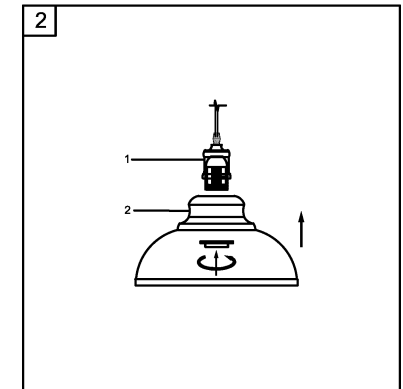

3. Install lighting bulbs (not included).

USE 120V E27  1*40W Max.

